

CITY OF ALEXANDRIA
704 Broadway
Alexandria, MN 56308
320.763.6678
email: permits@alexandriamn.city

**DRIVEWAY/SIDEWALK
PERMIT APPLICATION**

PERMIT NUMBER: ROW _____
DATE: _____
DATE OF REFUND: _____

Permit Fee: \$100.00
Deposit: \$300.00

DEPOSIT PAID BY: _____
**Notification of completion must occur within 30 days for a full deposit refund.
Failure to notify will constitute a deposit forfeit.**

If needed, the City of Alexandria will pay 50% toward culverts (material only; not to include labor or installation costs)

JOB INFORMATION

Property Owner: _____

Mailing Address: _____

Job Address: _____

Location: east _____ west _____ north _____ south _____ side of _____ **(please use attached map)**
(This right-of-way is dedicated to the public and is to be used primarily by street and utility personnel.)

Estimated Cost: \$ _____ Permit Expiration Date: _____ ROW Square Footage: _____

WORK BEING PERFORMED

_____ Construct new driveway _____ Construct new sidewalk _____ Alteration or addition

_____ Resurface existing driveway involving grade changes

_____ Other _____

Pavement material (circle one) asphalt concrete paving block other _____

Is there an existing concrete valley gutter? _____ yes _____ no

Work to start on or after _____ Date of completion _____

Soil compaction by ordinary compaction methods, material to be compacted in one (1) foot lifts; to 110% of original conditions.
Type and size of compaction equipment _____

Asphalt bituminous oil content shall not be less than 6.5%.

If necessary to detour traffic, describe routing _____

Notify Police Department: _____ yes _____ no

Notify Gopher One (1-800-252-1166)

See page 2

AUTHORIZED BY

Date: _____

Authorized by: _____
Public Works Coordinator

Date: _____

Approved by: _____
Public Works Coordinator

Date: _____

Approved by: _____
Brian Dahl / ALP

REGULATIONS & INFORMATION

1. Driveways shall not intersect a street corner curb line or edge of the traveled way or be closer than 60 feet to the intersection of the extended street curb lines.
2. Each driveway shall not exceed 36 feet in width at their intersection with a street travel way in a commercial zone.
3. Each driveway shall not exceed 24 feet in width at their intersection with a street travel way in a single-family zone.
4. Driveways shall be no closer together than 10 feet measured along a street right-of-way.
5. Driveways shall be no closer to a side lot line than 5 feet at the edge of the right-of-way, unless the driveway is jointly used by the adjoining properties.
6. Driveways shall be paved or otherwise stabilized.
7. All dimensions must be noted for the width of drive and green areas. This will include dimensions at roadway and property line.
8. The minimum fee shall be \$50.00, with a \$300.00 refundable deposit, both payable at time of application.

CONTRACTOR'S AFFIDAVIT

I/We certify that all the foregoing information is accurate and that all work must be done in compliance with all applicable laws regulating construction and zoning to the satisfaction of the City. I/We further agree to assume all liability for, and save the City harmless from, any and all claims for damages, actions or causes arising out of the work to be done under this applicant and permit.

- Deposit will be returned by the City upon satisfactory completion of the restoration of the street or right-of-way, as determined by the City.
- **NOTIFICATION OF COMPLETION MUST OCCUR WITHIN 60 DAYS FOR A FULL DEPOSIT REFUND. FAILURE TO NOTIFY THE CITY WITHIN 60 CALENDAR DAYS WILL CONSTITUTE A DEPOSIT FORFEIT.**
- For work performed after October 15, the deposit will be retained until satisfactory completion the following year (approximately May 20th). I/We understand **THERE WILL BE A FINAL INSPECTION** of the work permitted herein. Compliance will be strictly enforced.
- **NO WORK WHATSOEVER WILL COMMENCE UNTIL THE PERMIT HAS BEEN ISSUED.**
- The permit fee will be **DOUBLED** if work is started without an approved permit.
- The permittee further understands that only licensed contractors may be employed.

Dated: _____ Print Name of Applicant: _____ Signature: _____

CONTRACTOR INFORMATION

Contractor: _____ Telephone: _____

Address: _____ City _____ State _____ Zip _____

State Cert/CC Comp Card # _____ Job Representative: _____

FOR CITY USE ONLY:

In consideration of this application and agreement to comply in all respects with the regulations of the City covering such operations, permission is hereby granted for the work to be done as described in the above application, said work to be done in accordance with Special Provisions required as detailed. It is expressly understood that this permit is conditioned upon replacement or restoration of the street and boulevard to its original or improved condition.

CITY OF ALEXANDRIA DRIVEWAY PERMIT

PROVIDE THE ACTUAL DIMENSIONS OF THE DRIVEWAY AND DISTANCE DRIVEWAY IS FROM PROPERTY CORNERS AT APPROPRIATE PLACES ON DRAWING.

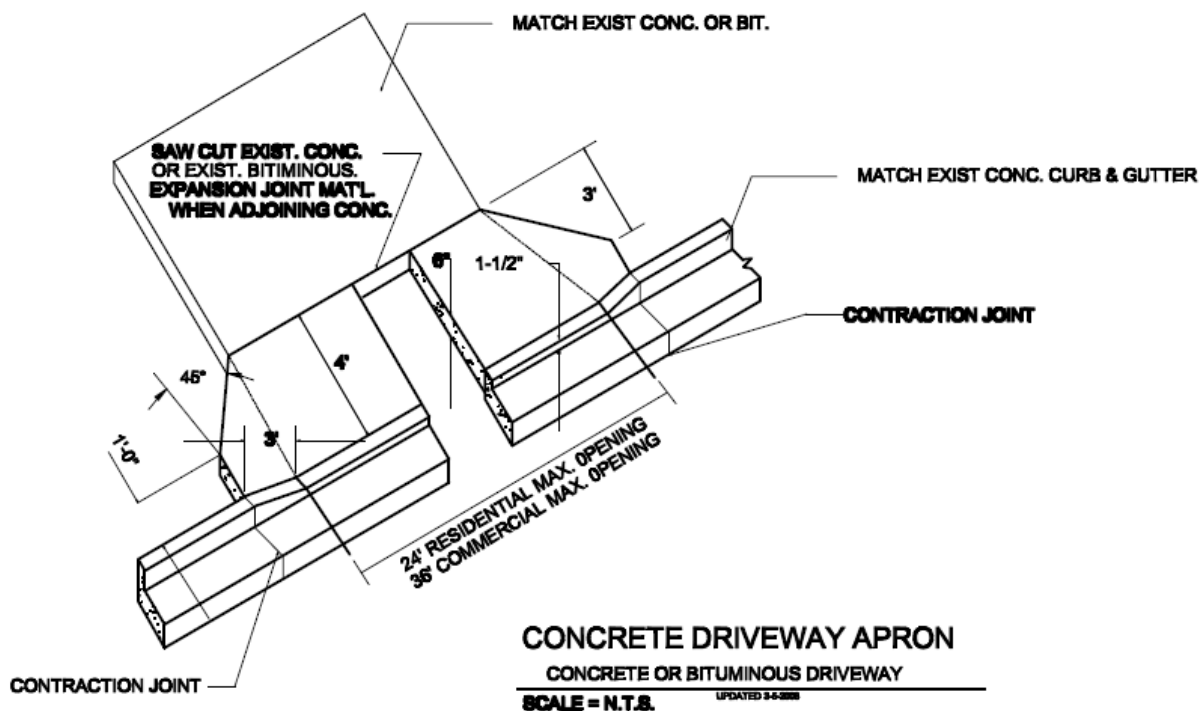
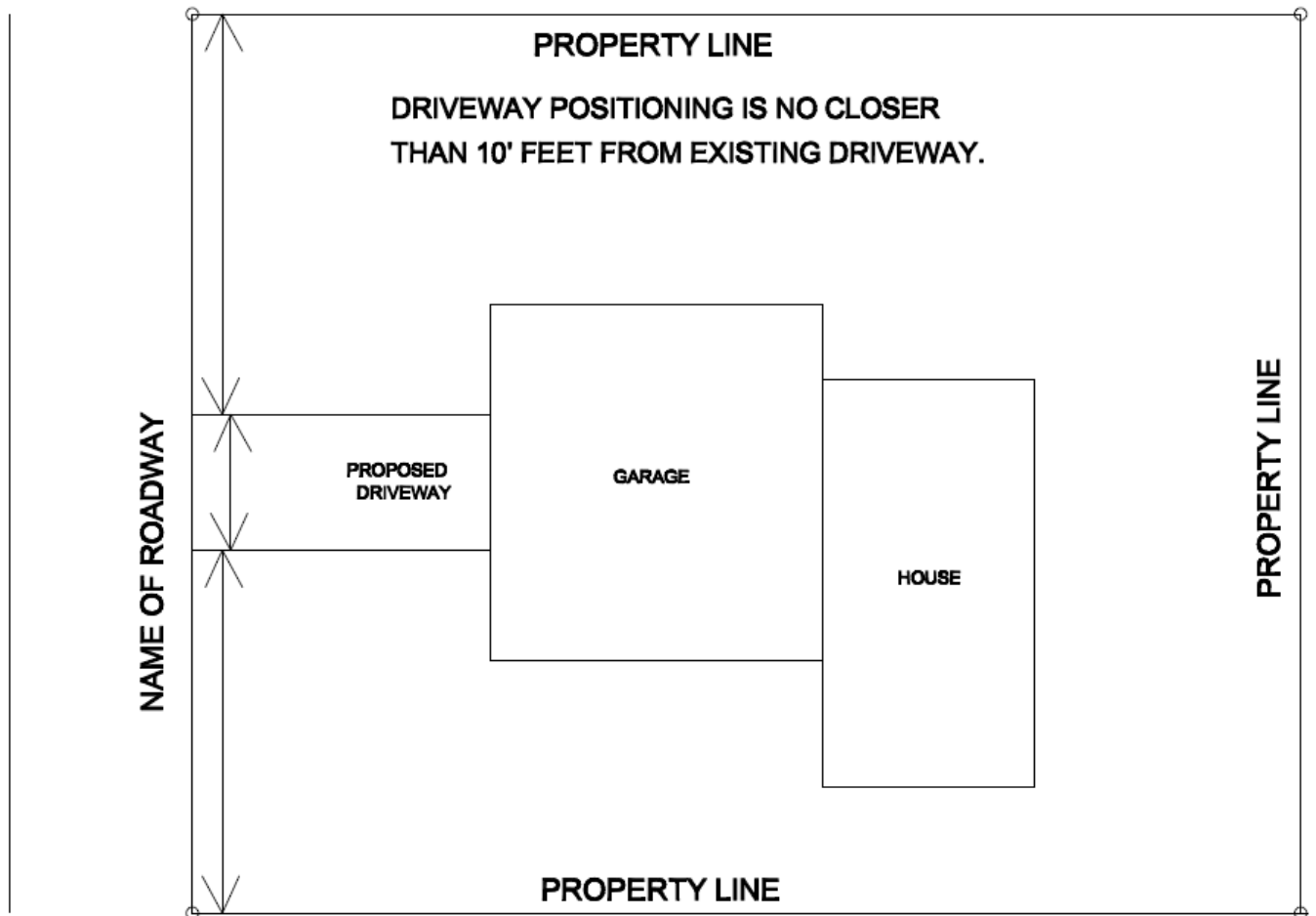

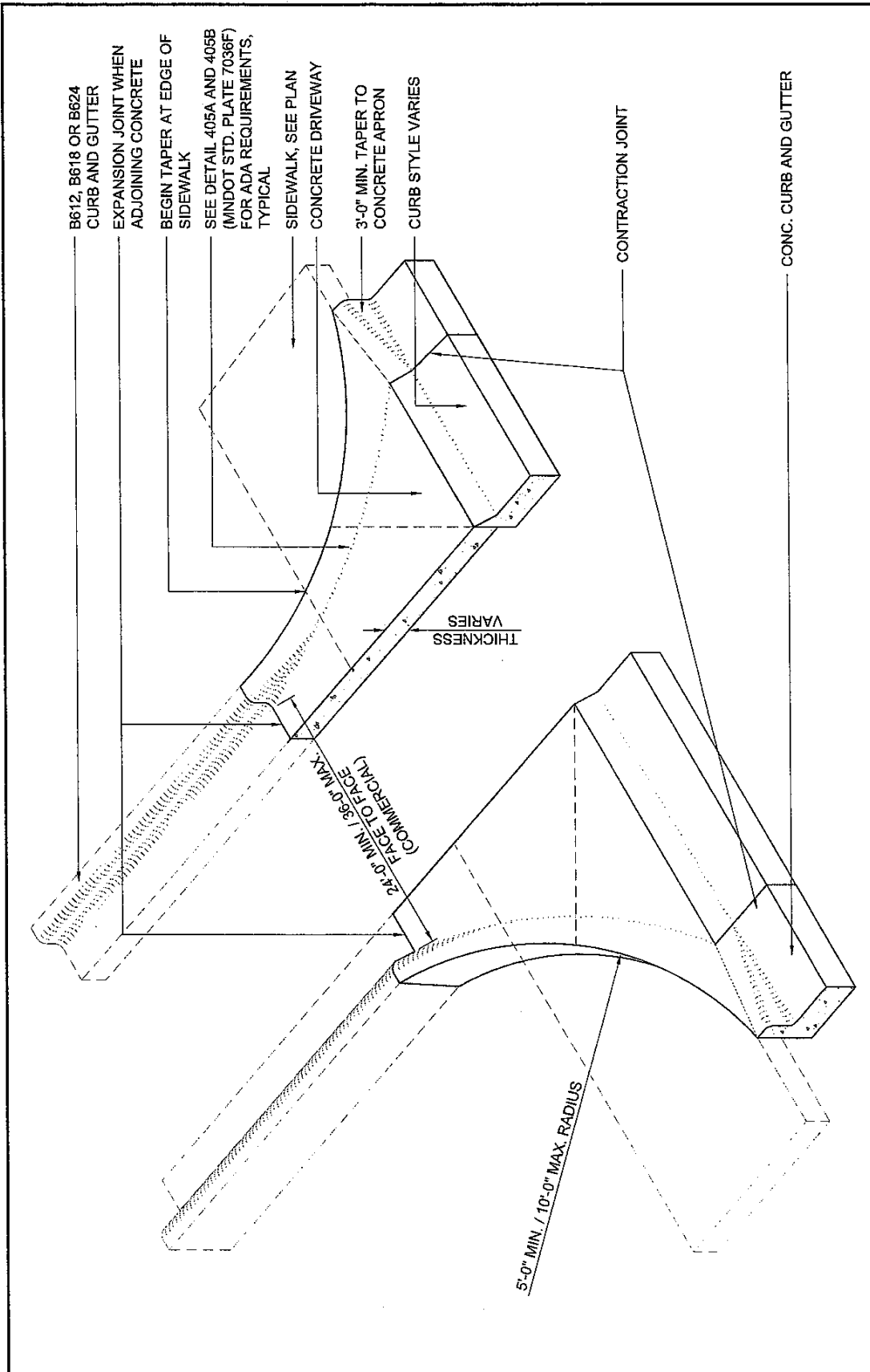

B612, B618 OR B624
CURB AND GUTTER

EXPANSION JOINT WHEN
ADJOINING CONCRETE

BEGIN TAPER AT EDGE OF
SIDEWALK

SEE DETAIL 405A AND 405B
(MNDOT STD. PLATE 7036F)
FOR ADA REQUIREMENTS,
TYPICAL

SIDEWALK, SEE PLAN
CONCRETE DRIVEWAY

3-0" MIN. TAPER TO
CONCRETE APRON

CURB STYLE VARIES

THICKNESS
VARIES

24.0" MIN. / 36.0" MAX.
FACE TO FACE
(COMMERCIAL)

5'-0" MIN. / 10'-0" MAX. RADIUS

CONTRACTION JOINT

CONC. CURB AND GUTTER



CITY OF ALEXANDRIA
704 BROADWAY
ALEXANDRIA, MN 55308
PH: (630)763-4678 FAX: (630)763-3511

CONCRETE DRIVE APRON
© 2008 WILDETT SMITH NOTTING

REVISION
12/23/2008

DETAIL NO.
401B

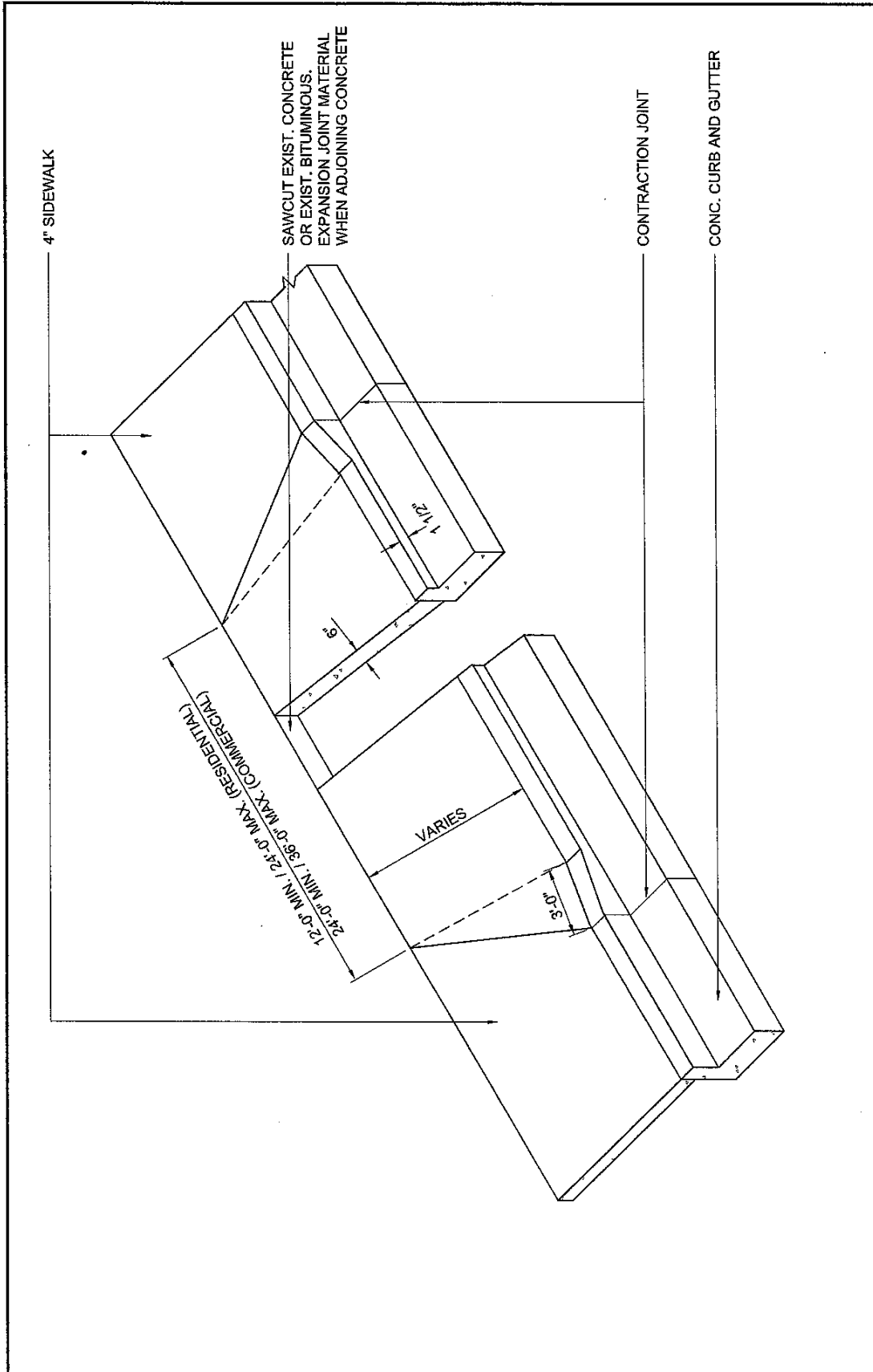

	CITY OF ALEXANDRIA 704 BROADWAY ALEXANDRIA, MN 55308	PH: (320)763-6578 FAX: (320)763-3511	CONCRETE DRIVEWAY APRON © 2008 WIDSETH SMITH HOLDINGS	REVISED 12/23/2008	DETAIL NO. 402A
---	--	---	--	-----------------------	--------------------